



Slant-Bed Turning Center

Multi-Tasking Series



鈺基科技股份有限公司
ACCUWAY MACHINERY CO., LTD.

42942 台灣台中市神岡區豐工中路31號

No.31, Fenggong Central Rd., Shengang Dist., Taichung City 42942, Taiwan

TEL: +886-4-2520-9588 FAX: +886-4-2520-9716

E-mail: market@accuway.com.tw



Multi-tasking Slant Bed Turning Center

- Twin spindle design for simultaneous front and back machining.
- Y-axis design for hybrid turning and milling compound machining.
- Strong and rigid power turret design to meet complex workpiece machining.



Two Spindle Single Turret
(Hydraulic/Servo)



Two Spindle Single Turret
(Power turret)



Two Spindle Single Turret
(Power turret + Y-axis)

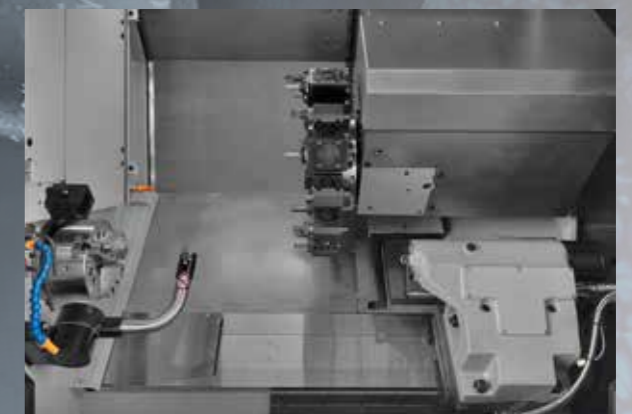

Single Spindle Single Turret
(Power turret + Y-axis)



UT-200S



UT-300SM



UT-200SY



UA-330LY

Robust Structure Design

Superior casting of meehanite

The UT-200 series has a 45° inclined bed, whereas the UT-300 series has a 30° inclined bed box structure, enabling smooth turret movement without vibrations. The center of gravity falls inside the base, ensuring rigidity during the heavy cutting process.

The base and guide rail, made of Meehanite gray cast iron, are integrally cast, hardened, and ground. They possess a wide rail span, low center of gravity, large bed swing, and high stiffness while delivering excellent drainage and chip removal performance. The base bed's interior has a heavily distributed strengthening ribs design, effectively eliminating deformation caused by shear and tensile stress.

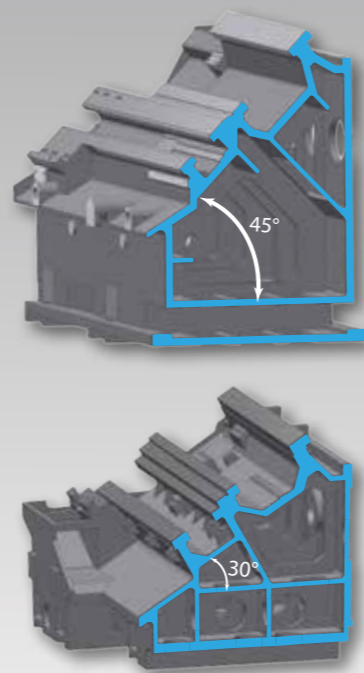

Meticulous hand-scraping work

The main spindle box and ball screw fixed base undergo a meticulous scraping process to calibrate and ensure geometric precision, meeting the dimensional stability required for long-term machining of the machine. Skilled scraping technicians create high and low texture distribution oil pockets on the sliding surface of the guide rails at the saddle base, reducing wear and heat generation on the contact surface, allowing for precise sliding without sticking.



Low backlash ballscrew drive mechanism

Pre-tensioned ballscrews and heat suppression designs eliminate backlash and thermal elongation. Direct servo motor drive improves axial feed positioning accuracy.

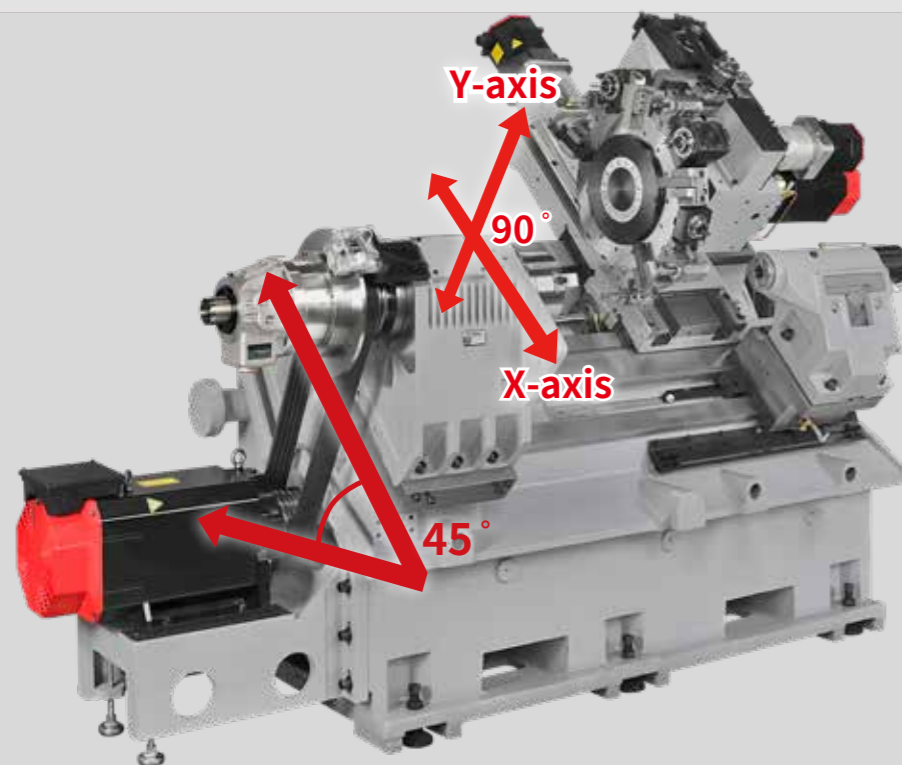

UT-200 series

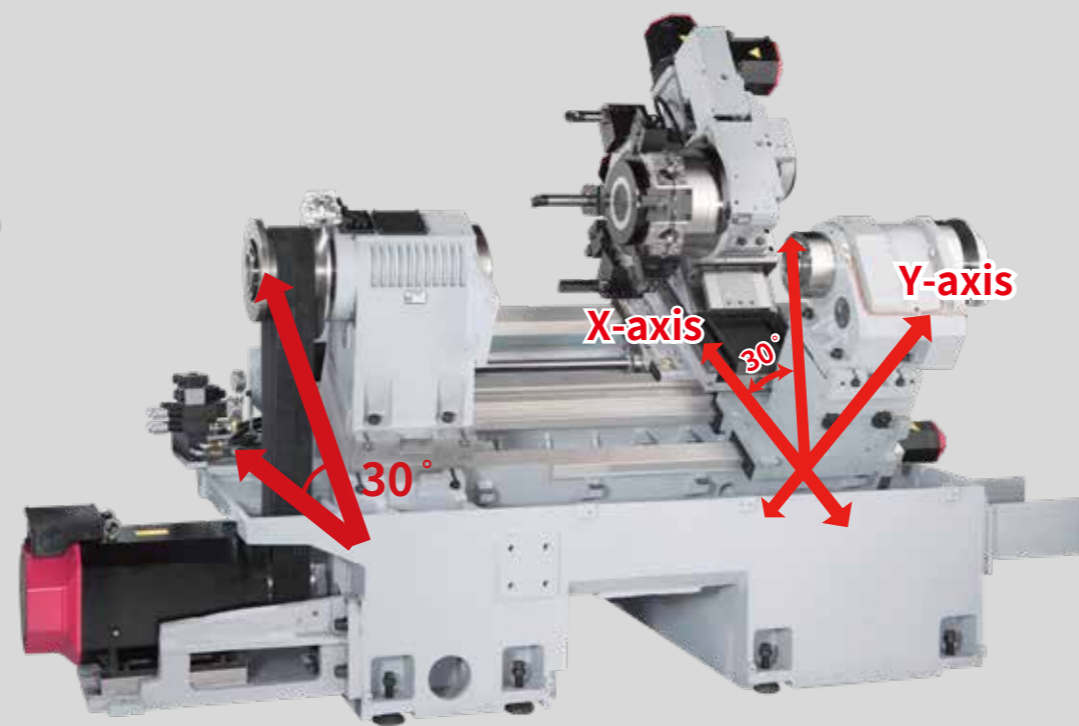

UT-300 series

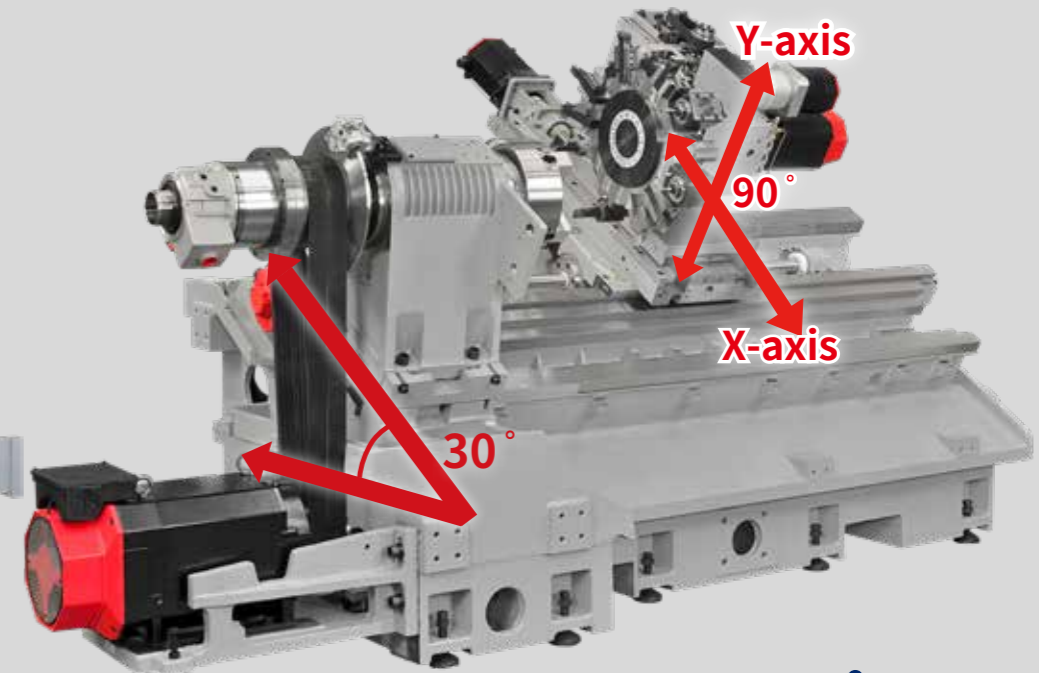

UA-330 series

Professional Precision Twin Spindle Design

Dual spindle and dual C-axis synchronized processing

The sub-spindle has independent axial drive capability, synchronous parts interchange control with the main spindle. The dual C-axis synchronized processing function makes it easier to perform milling, drilling, and threading on both the front and back sides of the workpiece, all within a single machine. This enhances production efficiency and machining precision.

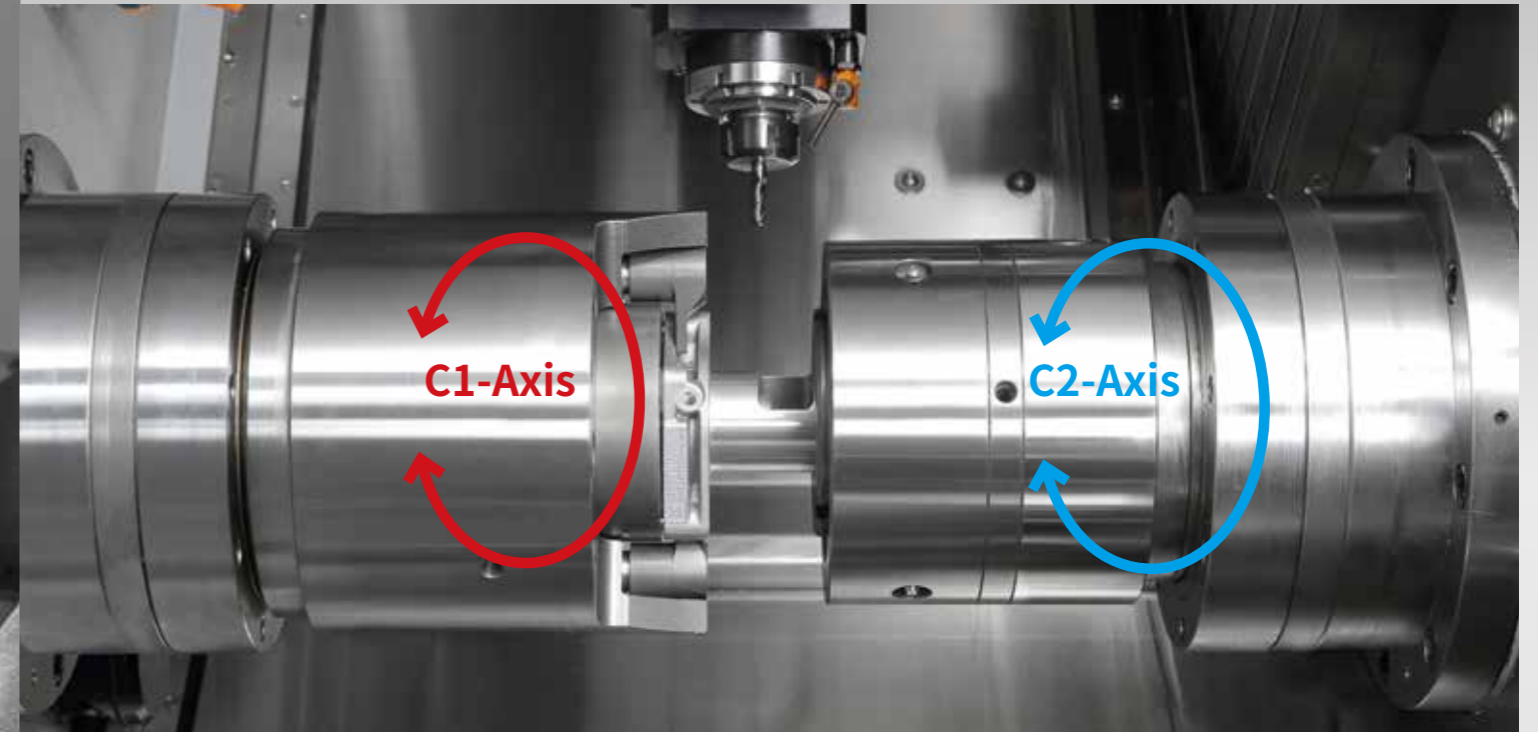

The self-designed and assembled belt-driven spindles all undergo ISO 1940 G1 grade dynamic balance calibration, paired with carefully designed pulley speed ratios, providing features such as high rotational precision, low vibration noise, and high torque output. The spindle box adopts a symmetrical heat dissipation rib design, effectively eliminating thermal deformation, and meets the high-precision requirements for roundness and concentricity through rigorous control of boring and grinding processes.

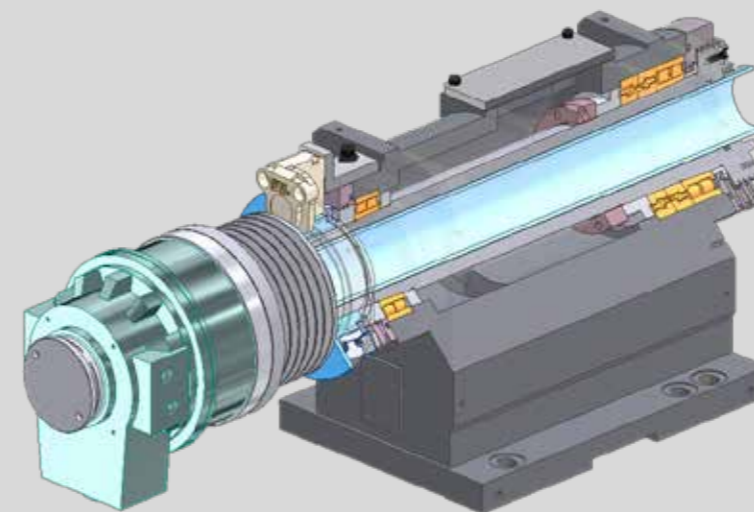

Belt-driven spindle(st.)

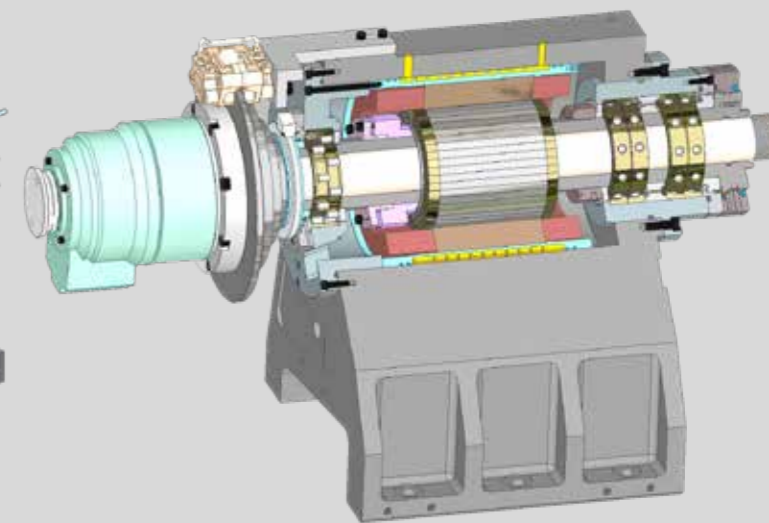

Built-in motor driven spindle(op.)

High-Precision Self-Made Turrets

BMT Power turret

The use of high-precision 3-piece helical couplings, driven by servo motors for tool positioning, results in short tool change times, high positioning accuracy, low failure rates, easy maintenance, and excellent reliability. Equipped with a 12/15-station power turret and a special lubrication circuit design, it supports extended uninterrupted machining with powered tools, meeting the demanding requirements of turning and milling composite processing.



VDI Power turret

Utilizing the tooth engagement between the spline and the tapered wedge-type clamping block locks the tool holder in place, allowing for faster tool holder correction and installation. This results in high production efficiency, user-friendliness, and reduced production costs.

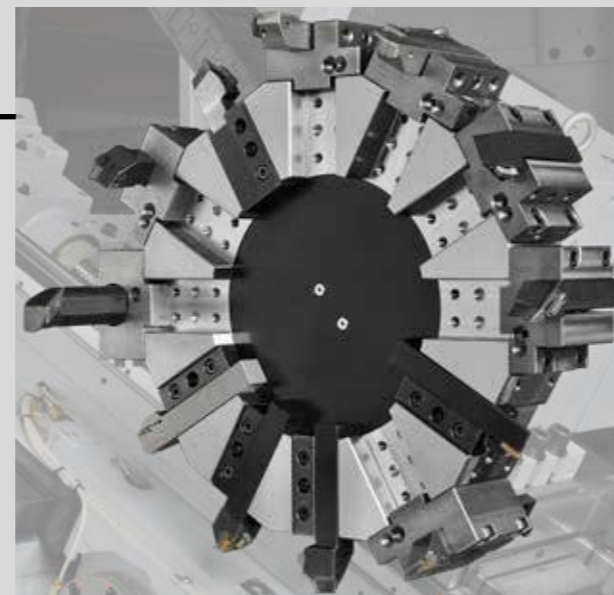

Hydraulic turret

Utilizing high-precision helical couplings, a hydraulic motor drives tool disc rotation, and precise positioning is achieved through cam-controlled tool-changing mechanisms. The tool disc can accommodate tool holders with 8/10/12 positions, resulting in low failure rates, easy maintenance, and no tool misalignment. Furthermore, if equipped with a special cutting water nozzle structure, it can withstand high pressures of up to 20 bar.

Programmable Tailstock

The tailstock quill features a high-precision inner sleeve design for precise positioning. The tailstock body's positioning and quill movement can be controlled programmatically through the M-code. Additionally, an option is available to use a hydraulic rod driven by a Z-axis servo motor for even more flexible and precise positioning.

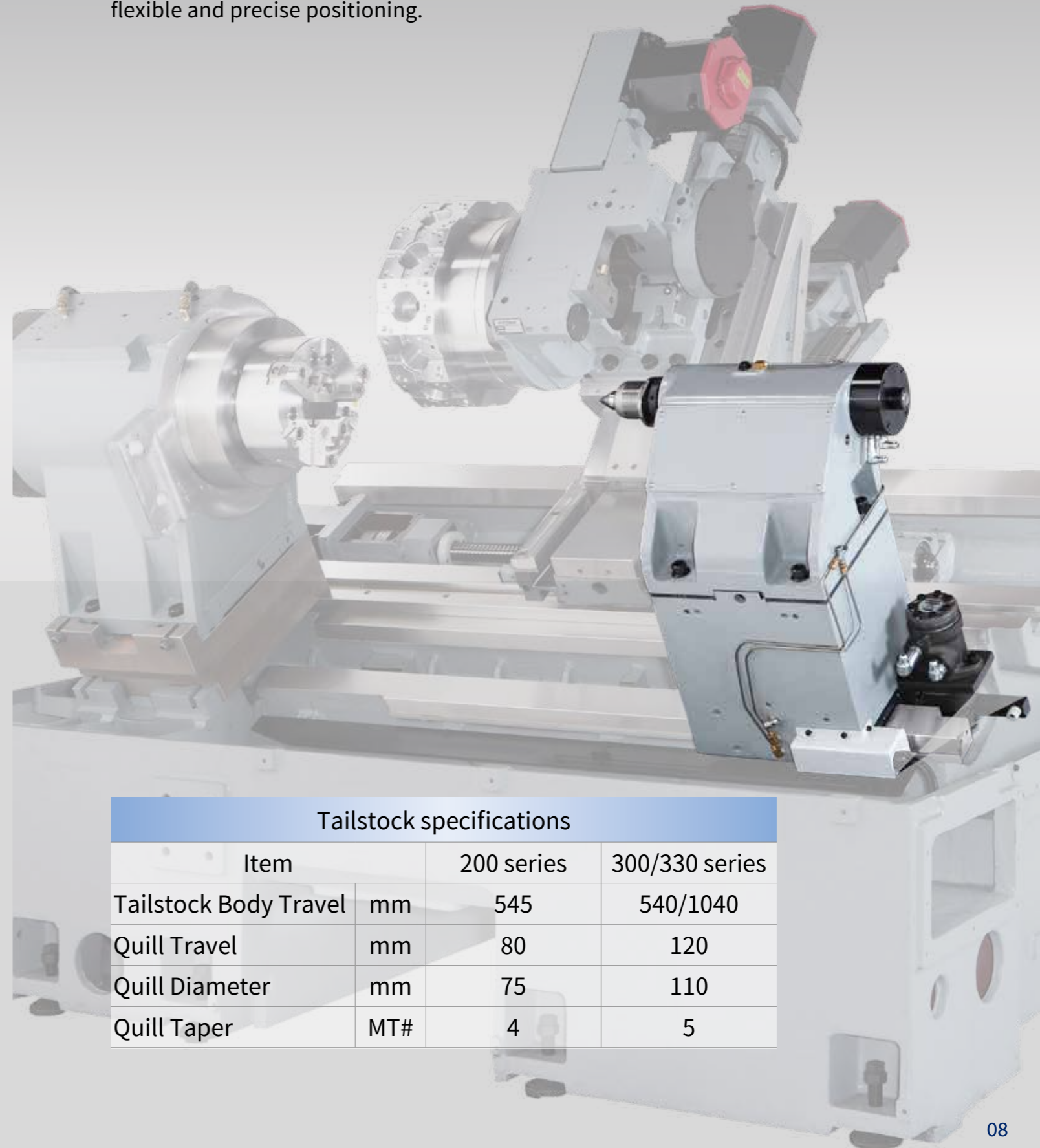

Tailstock specifications			
Item		200 series	300/330 series
Tailstock Body Travel	mm	545	540/1040
Quill Travel	mm	80	120
Quill Diameter	mm	75	110
Quill Taper	MT#	4	5

Y-axis Machining Capability

Y-axis Machining Capability

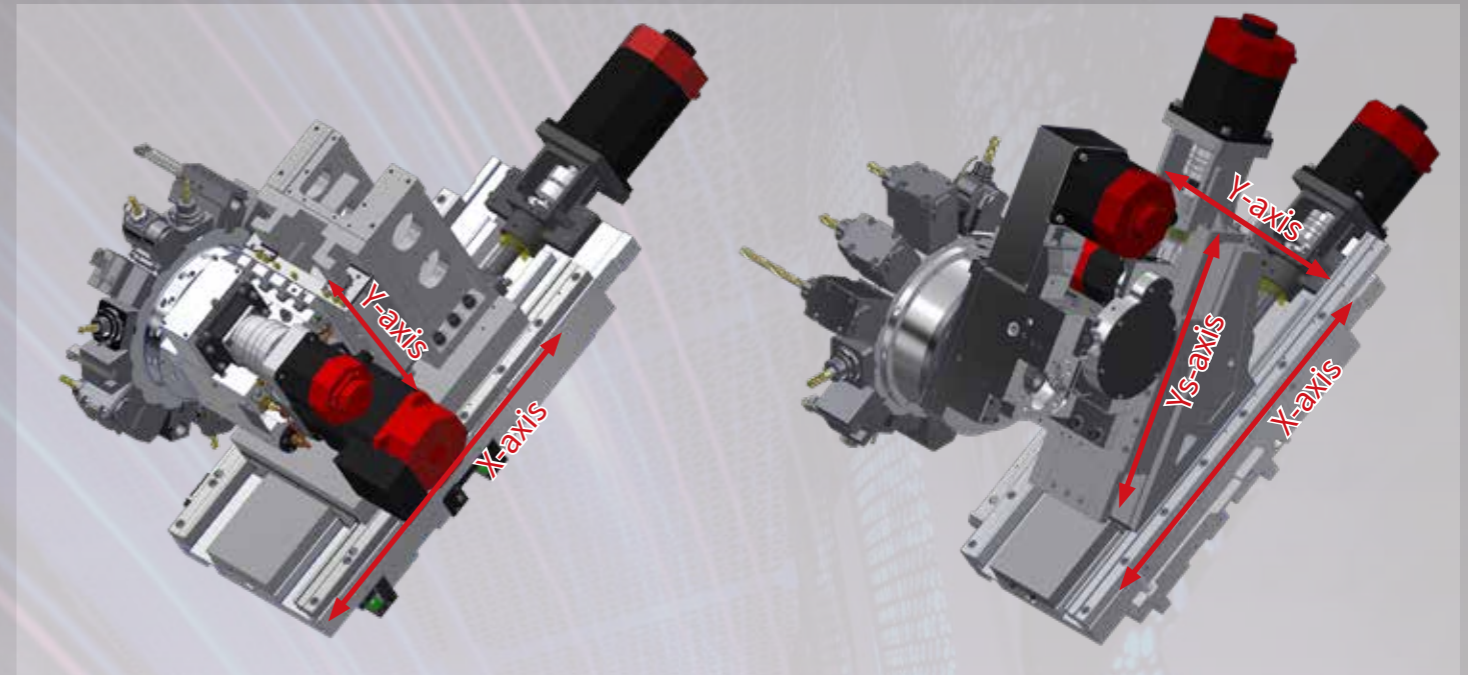
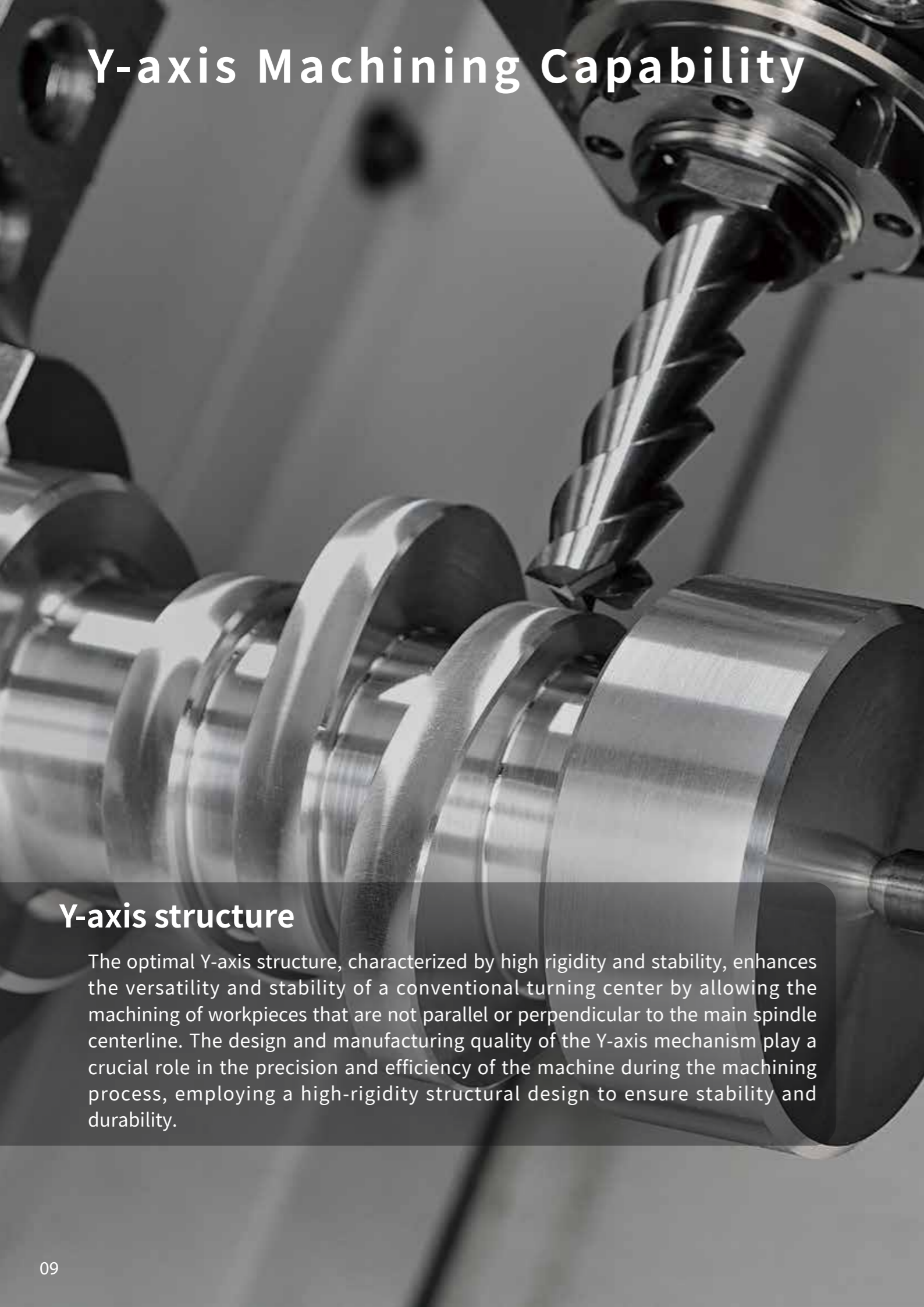

Independent Y-axis

Simultaneous independent motion control of Y-axis and X-axis.

Compound Y-axis

Synchronized compound Y-axis motion generated with YS-axis and X-axis.

Y-axis structure

The optimal Y-axis structure, characterized by high rigidity and stability, enhances the versatility and stability of a conventional turning center by allowing the machining of workpieces that are not parallel or perpendicular to the main spindle centerline. The design and manufacturing quality of the Y-axis mechanism play a crucial role in the precision and efficiency of the machine during the machining process, employing a high-rigidity structural design to ensure stability and durability.

Multi-axis turning and milling application

Contouring

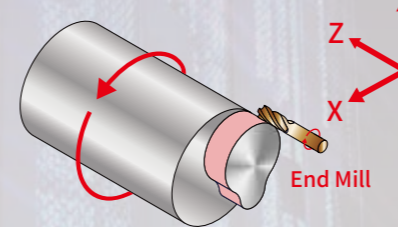

Helical Interpolation

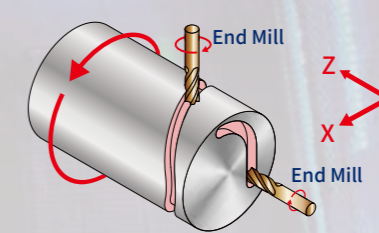

Symmetric Plane Machining

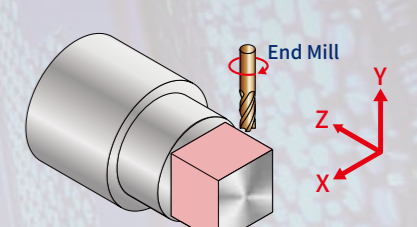

Large Pocket & Boss by Circular Interpolation

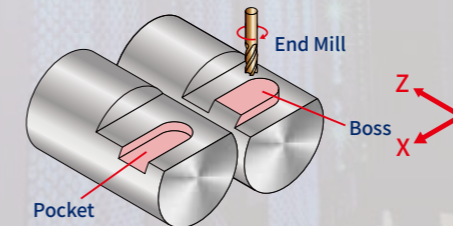

Basic Complex Machining

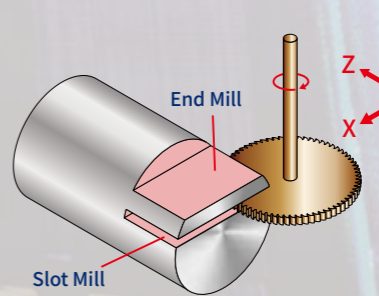

Off Center Cross Drilling & Tapping

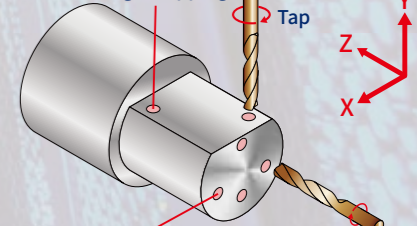

Off Center Face Drilling & Tapping

Optional Peripheral Equipment

Tool Setter

Utilizing manual or automated detection arms to monitor tool wear, correcting tool tip positions. The repeated positioning accuracy can reach $5\mu\text{m}$, ensuring stable machining quality, effectively reducing machine downtime, and enhancing production efficiency.

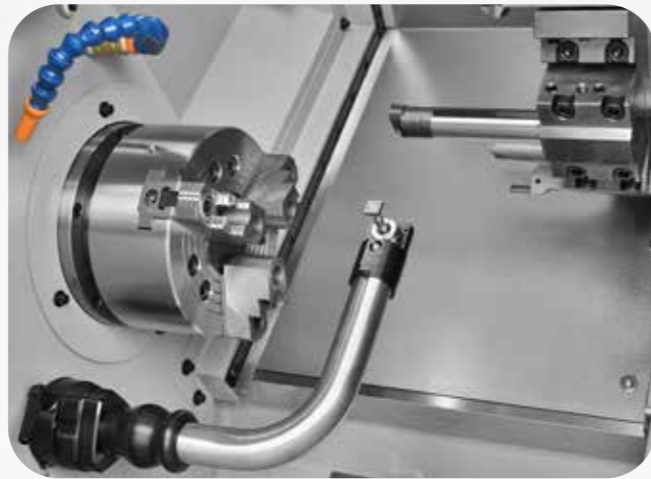

Oil-coolant Skimmer

Effectively separating oil contaminants from cutting fluid to prevent deterioration, extending its recycling lifespan, reducing waste, and simultaneously improving machining efficiency and product quality. This holds significant importance for environmental protection.

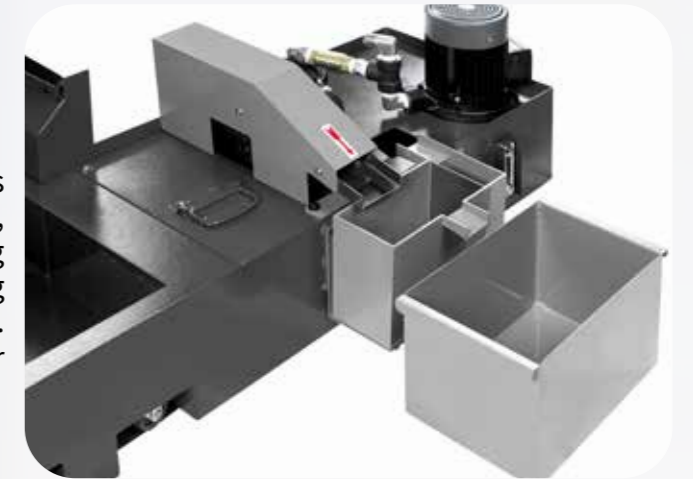

Parts Catcher

After finishing the machining cycle, the workpiece is automatically transferred to the collection box. With a bar feeder and parts conveyor, it can save labor costs through automatic production.

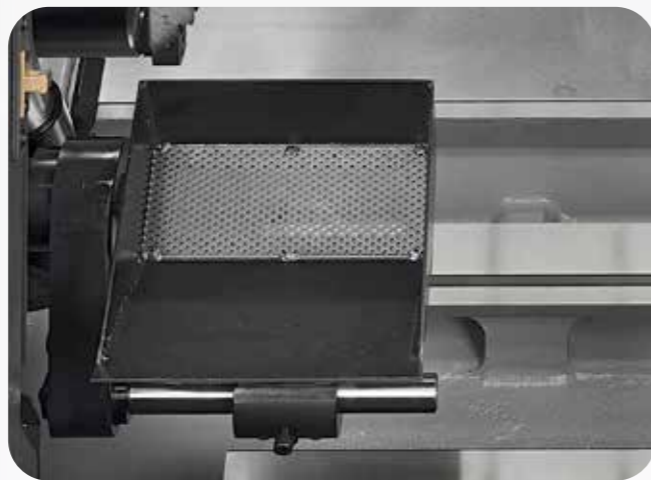

Oil Mist Collector

Filter, collect, and clean oil mist, dust, and water mist generated during the manufacturing process, allowing for the recycling of oils and gases produced during processing. This prevents the dispersion of toxic fumes and dust, safeguarding the health of personnel, saving costs, and protecting the environment.



Steady Rest

A movable pivot point reduces self-weight and centrifugal force effects on long workpieces, ensuring concentricity control. Main body travel can be hydraulic, servo-driven, or manual.



Linear Scale

Measuring the position of linear axes during servo motion to eliminate backlash, screw pitch error, or displacement errors caused by circulating ball screw heating, ensuring precise positioning and repeatability of the machine.



Optional Peripheral Equipment

Automation Integration

Combined with a gantry-type robotic arm and various workpiece pallet loading systems, it enables the automation of the production line. This not only reduces labor costs but also increases production efficiency, maintains machining dimensional stability, reduces workplace injuries and errors caused by manual operation, and enhances job safety.



UT-200S+Gantry Loader+ Plate Type Work Stocker



UA-200LY + Customized Bar feeders

Grippers



3-jaw vertical movement



3-jaw 180° grippers



2-jaw 90° grippers

WORK STOCKER



Stacking type

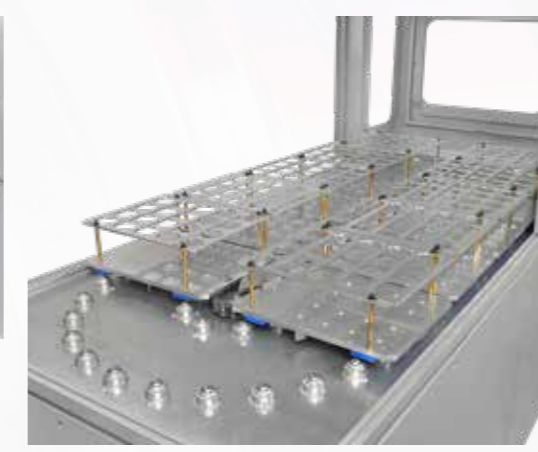

Plate Cyclic Type



Customized Bar Type

Optional Peripheral Equipment

Auto Door

When the machining cycle is complete, the door can automatically open, enhancing operational efficiency for personnel and, in conjunction with automated loading and unloading, providing an unmanned processing environment.

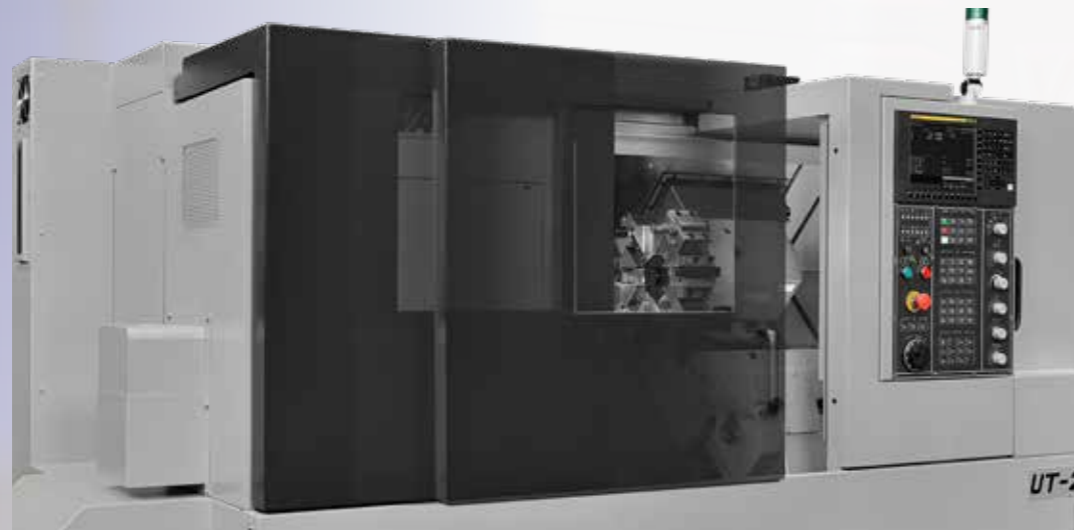

Bar feeder

By programming the machining cycle, the bar stock material is automatically fed into the main spindle, enabling long periods of unmanned continuous operation, increasing productivity, and reducing labor costs.



Spindle Power Chart

UT-200series ◊ UA-200series

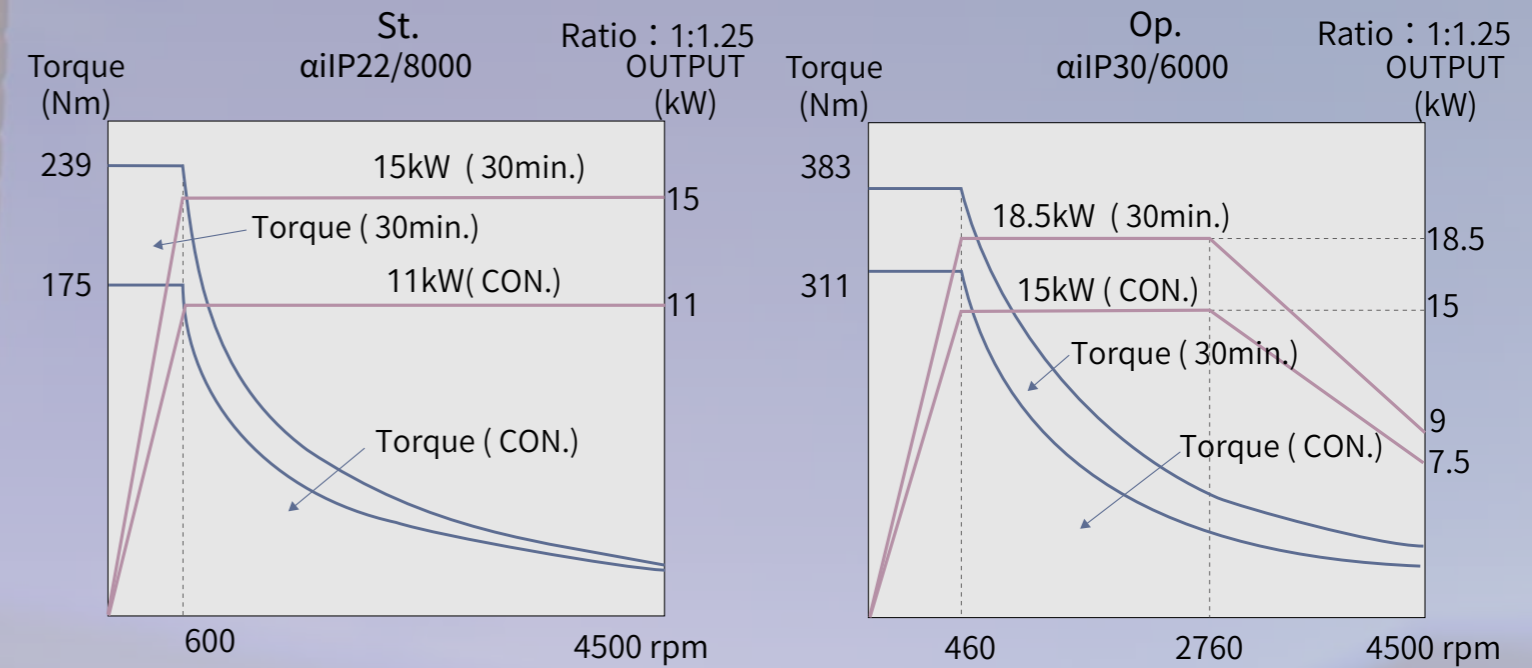

UT-300series ◊ UA-330series

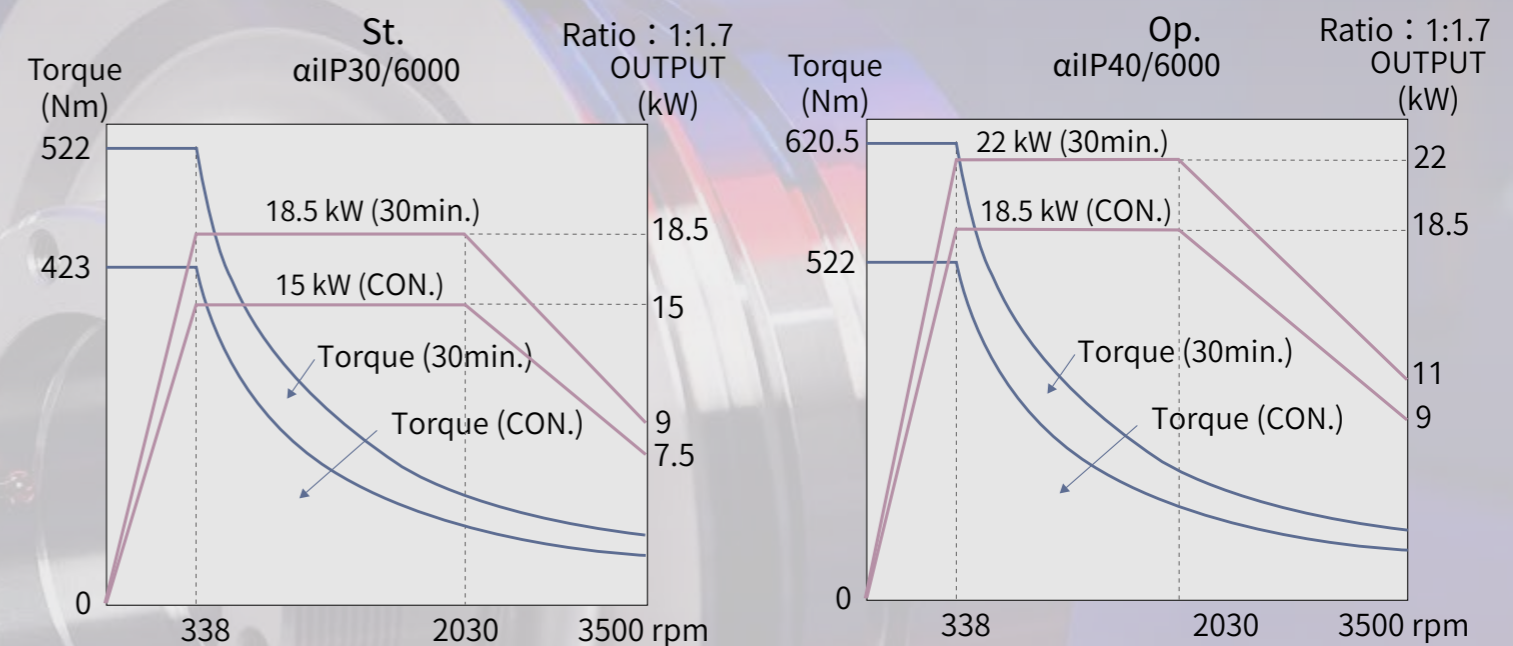

Tooling System Diagrams

UT-200S

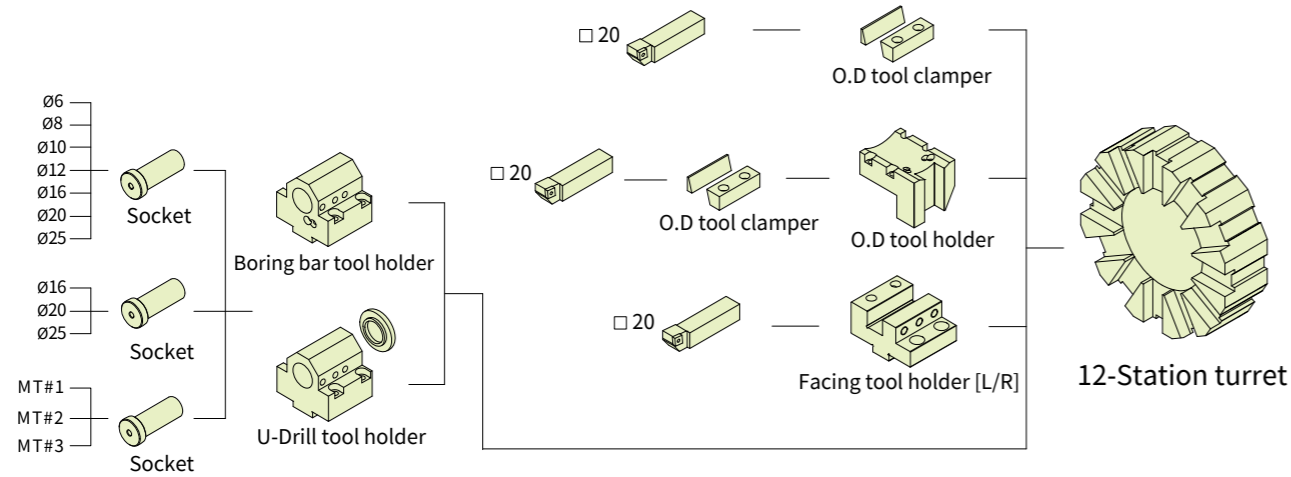

UT-200Y/UT-200SM / UT-200SY

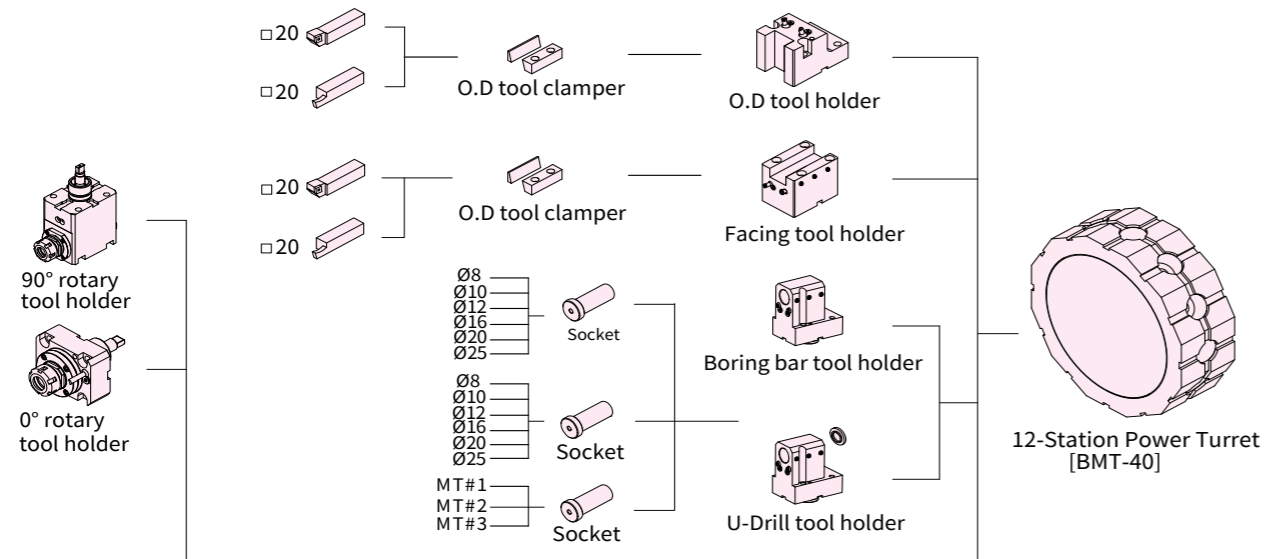

UA-200Y / UA-330Y

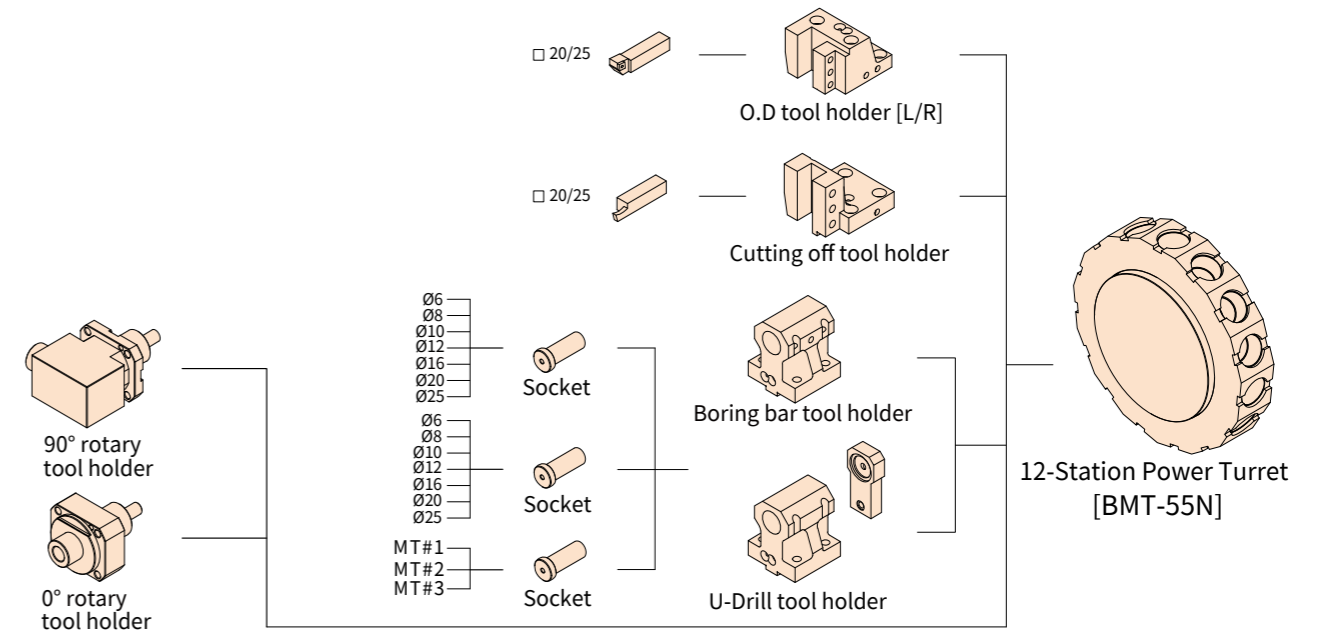

UT-300S

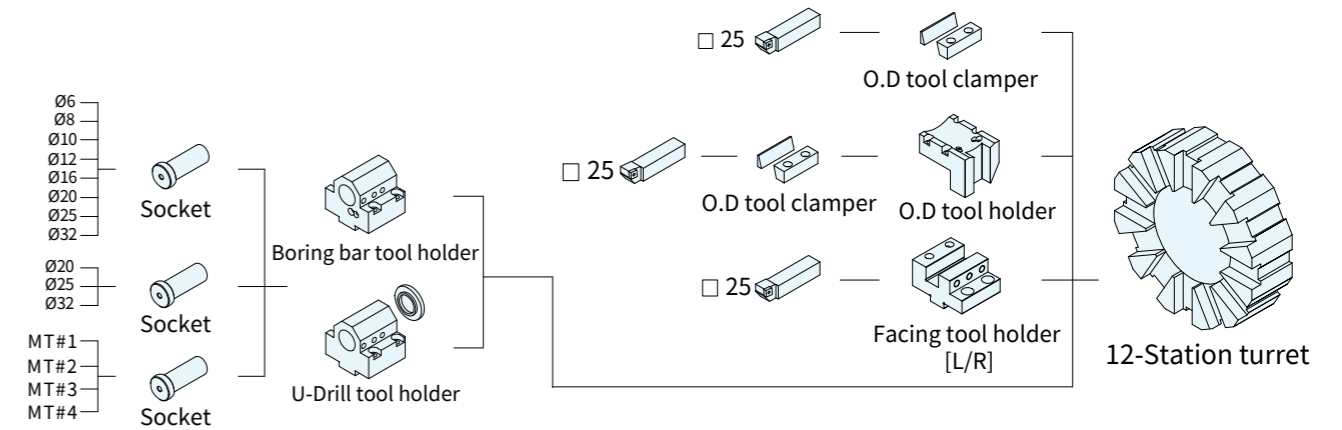

UT-300Y / UT-300SM / UT-300SY

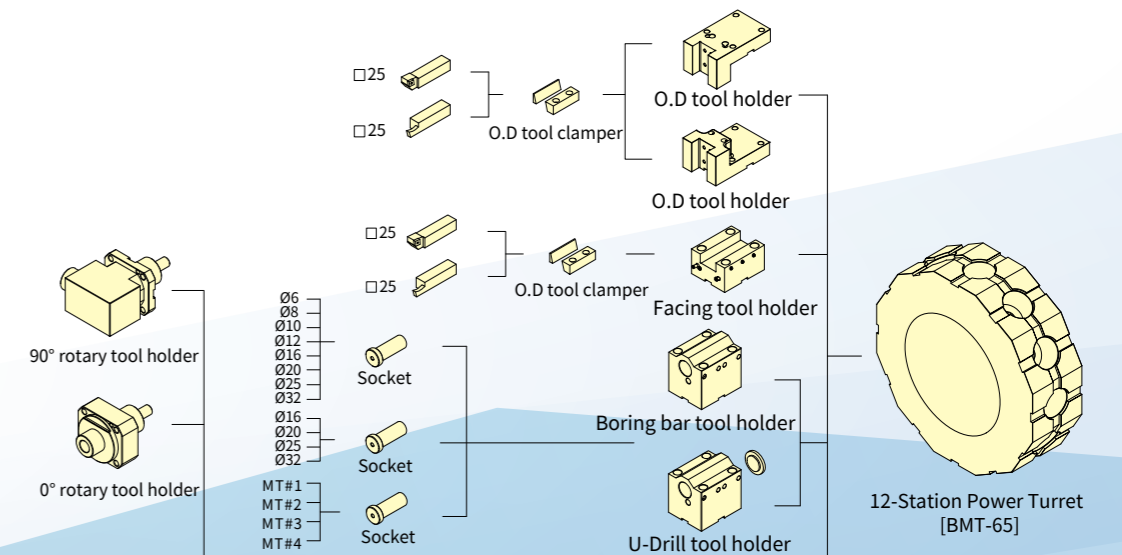

Tool Interference Diagrams

Unit:mm

UT-200 series

UT-200S

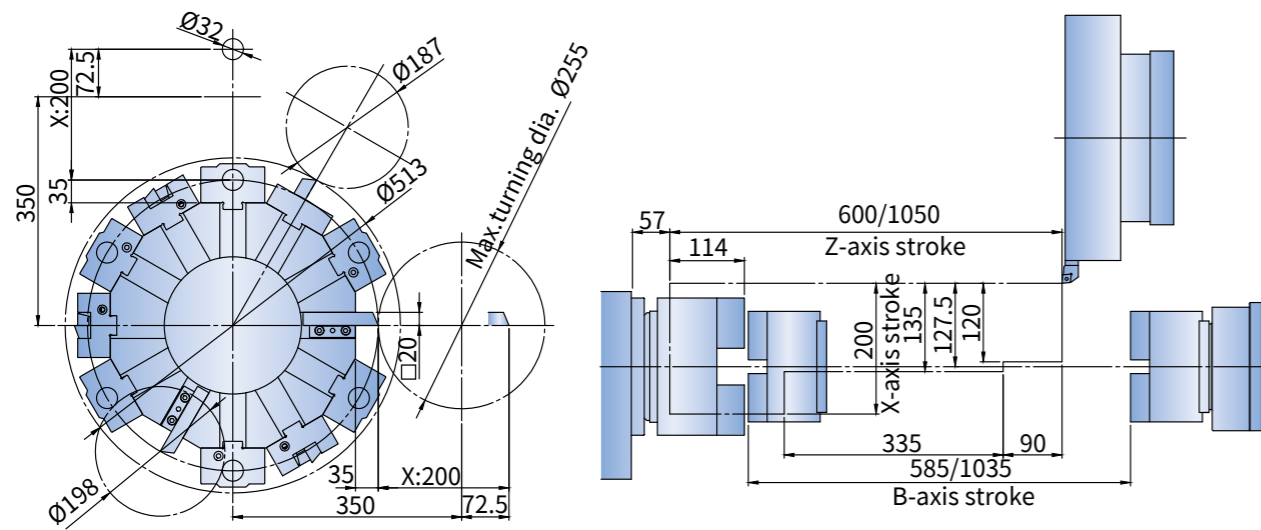

UT-200SM

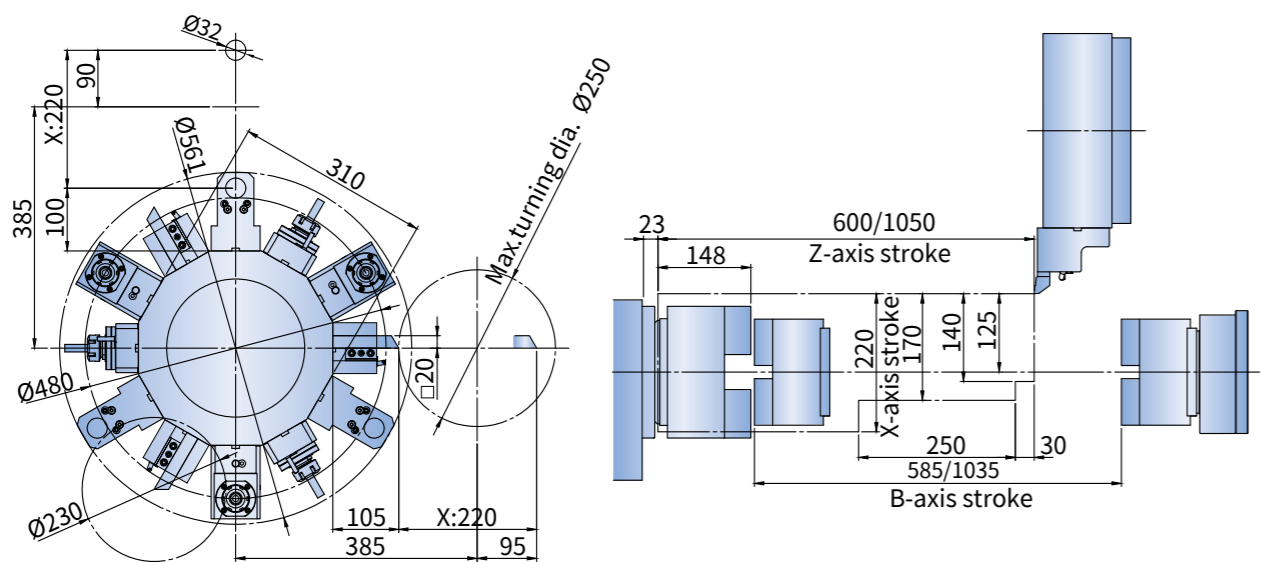

UT-200Y

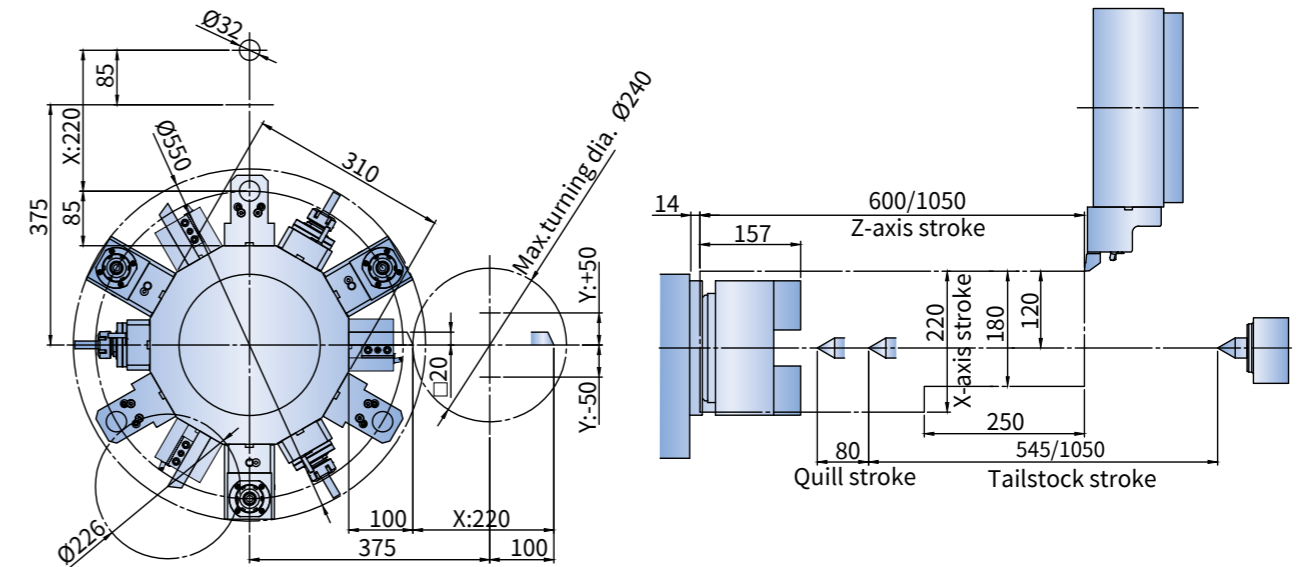

UA-200Y

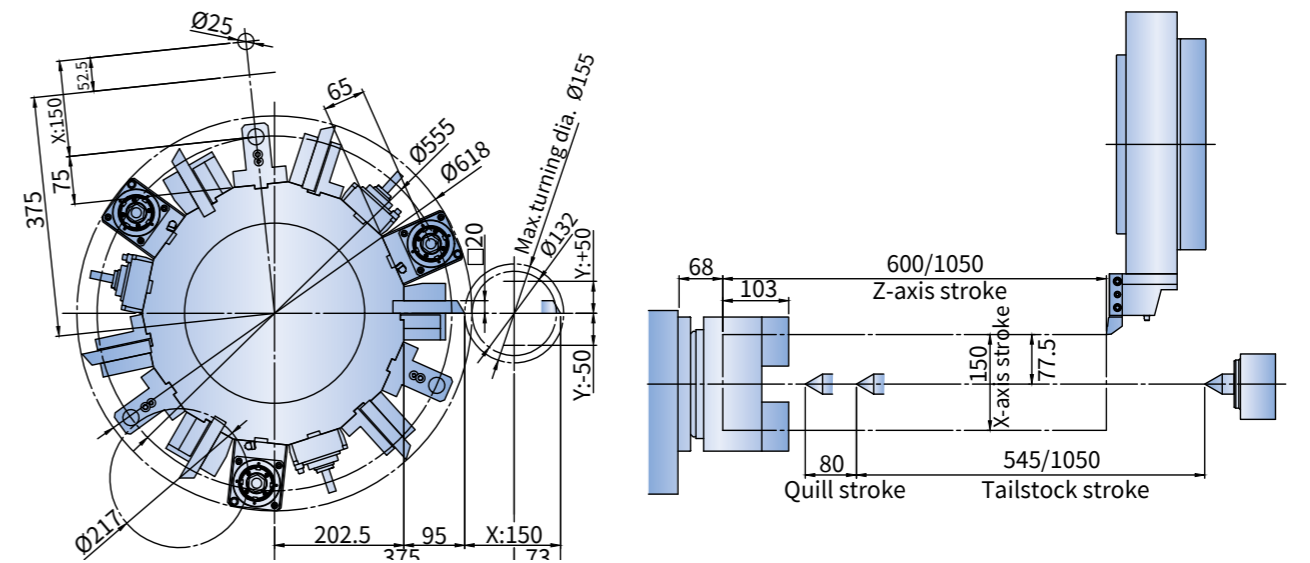

UT-200SY

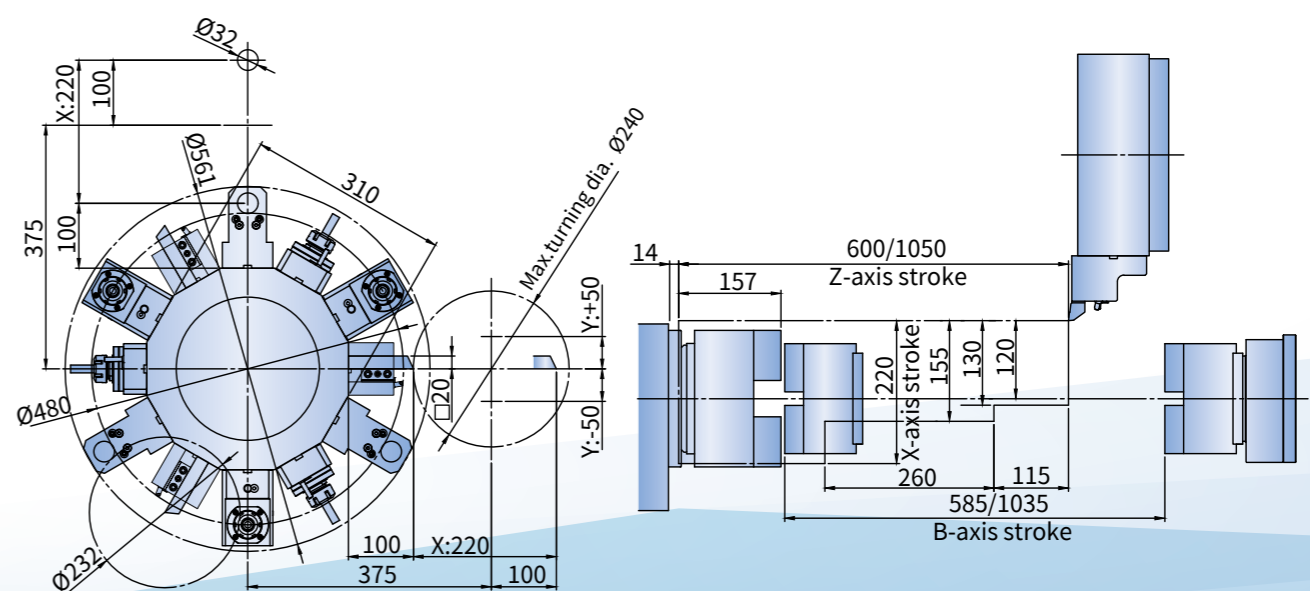

Tool Interference Diagrams

Unit:mm

UT-300 series

UT-300Y

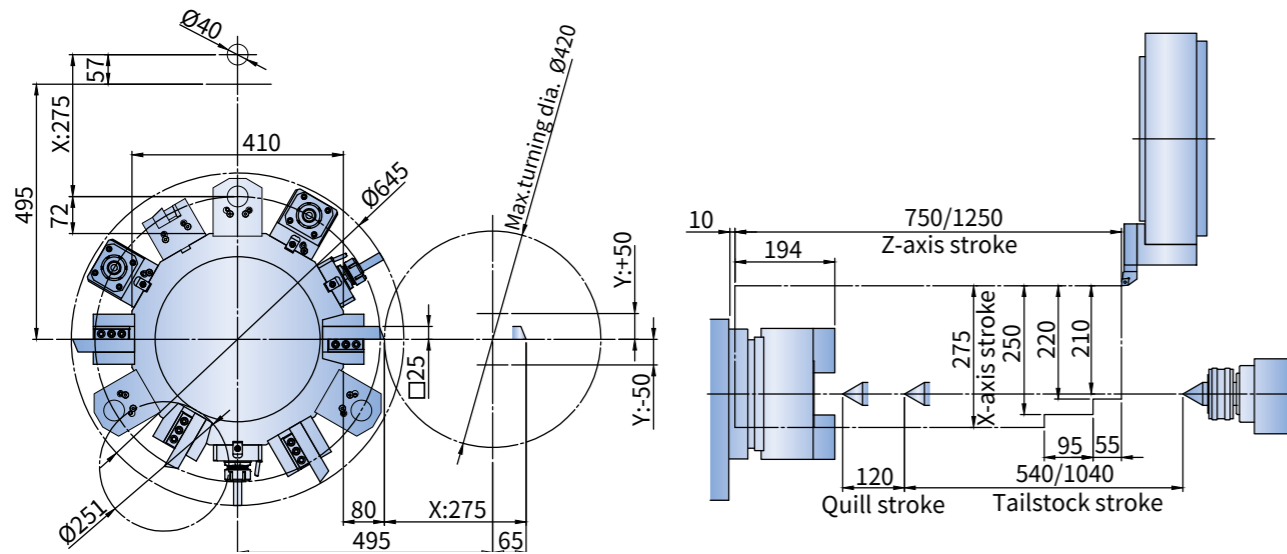

UT-300SM

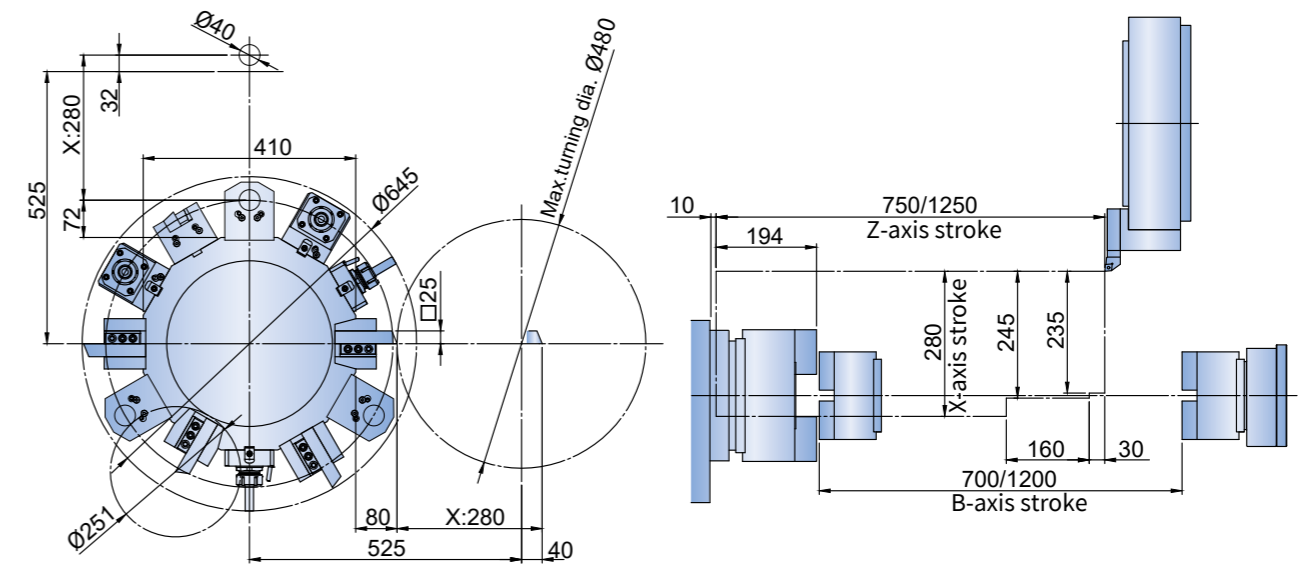

UT-300SY

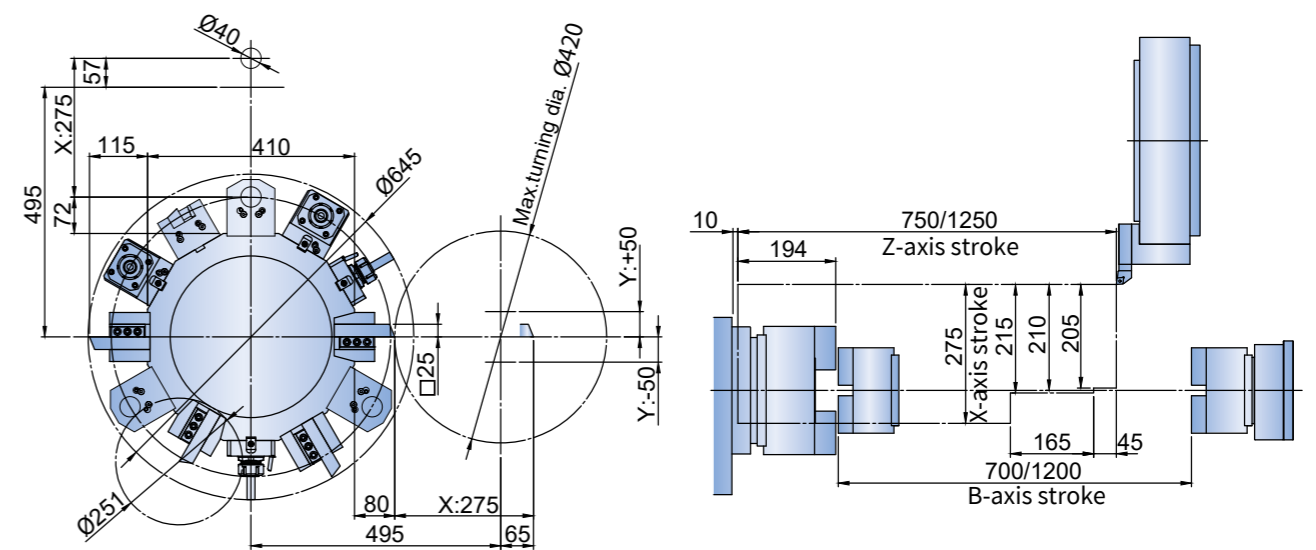

UT-300S

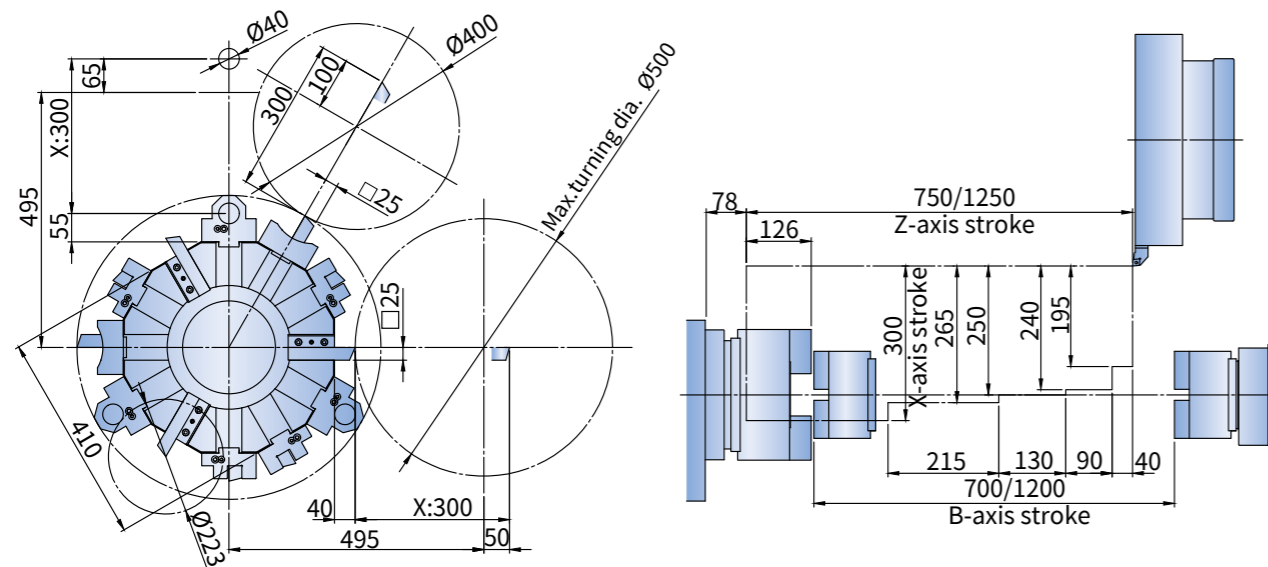

UA-330Y

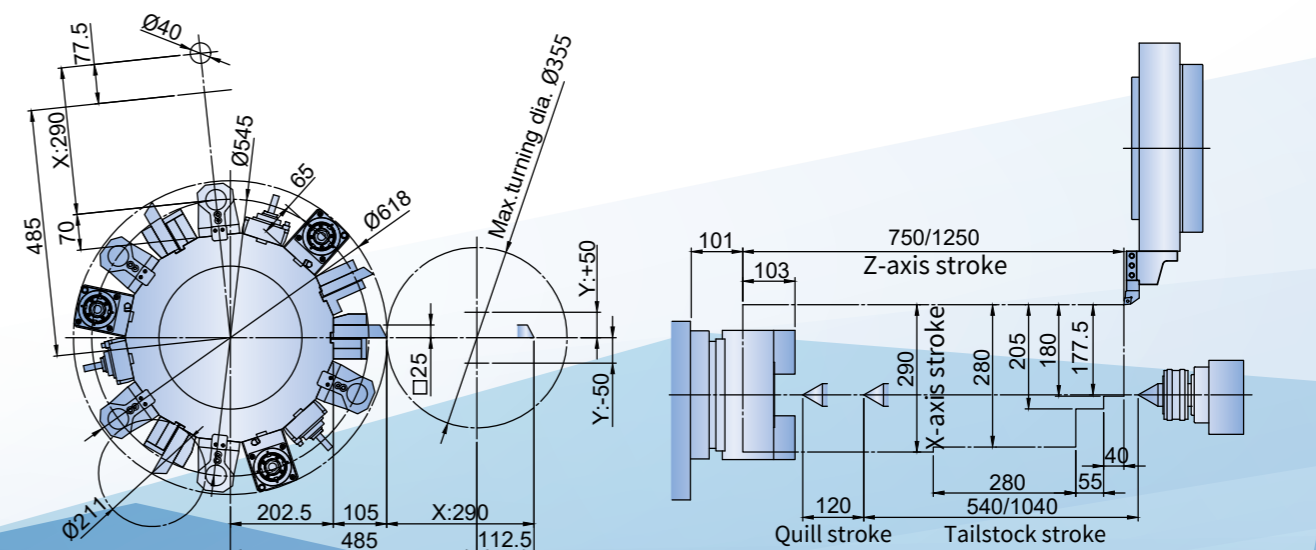

Machine Dimensions

Unit:mm

UT-200S/UT-200SM

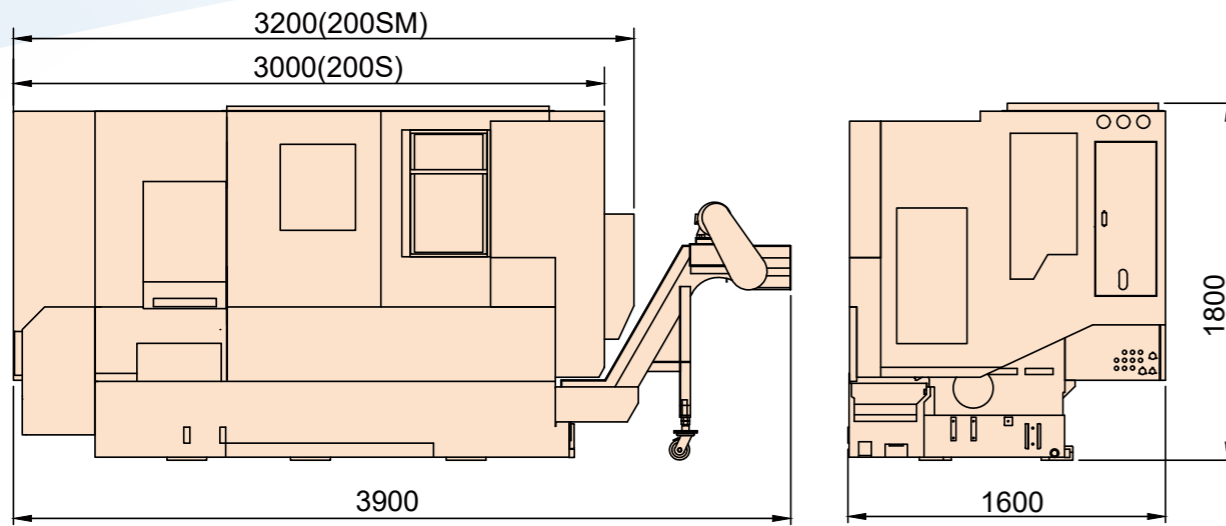

UT-300S/UT-300SM

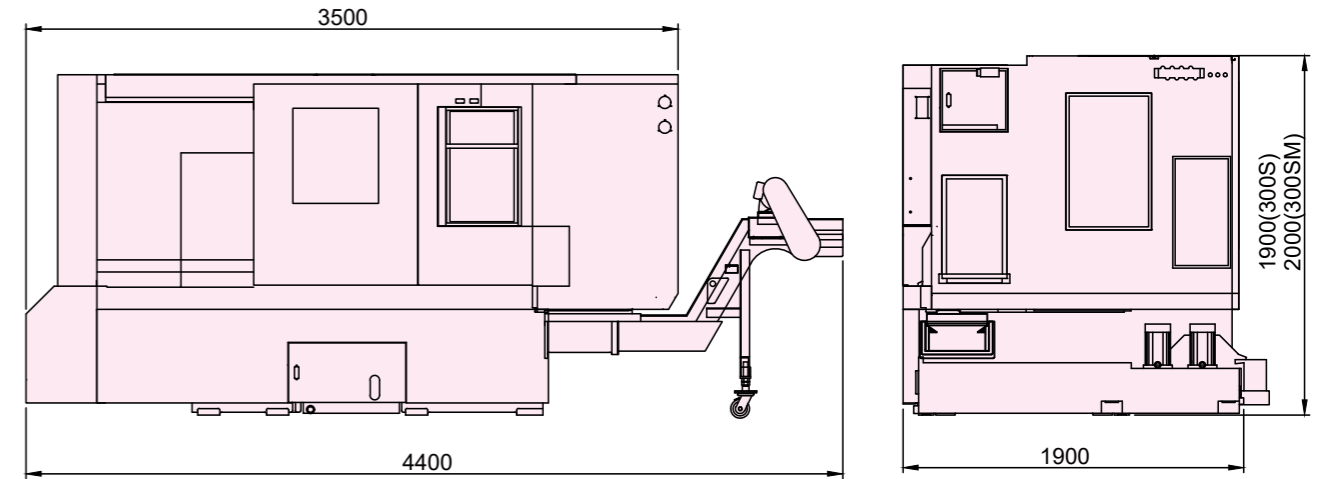

UT-200SY/UT-200Y

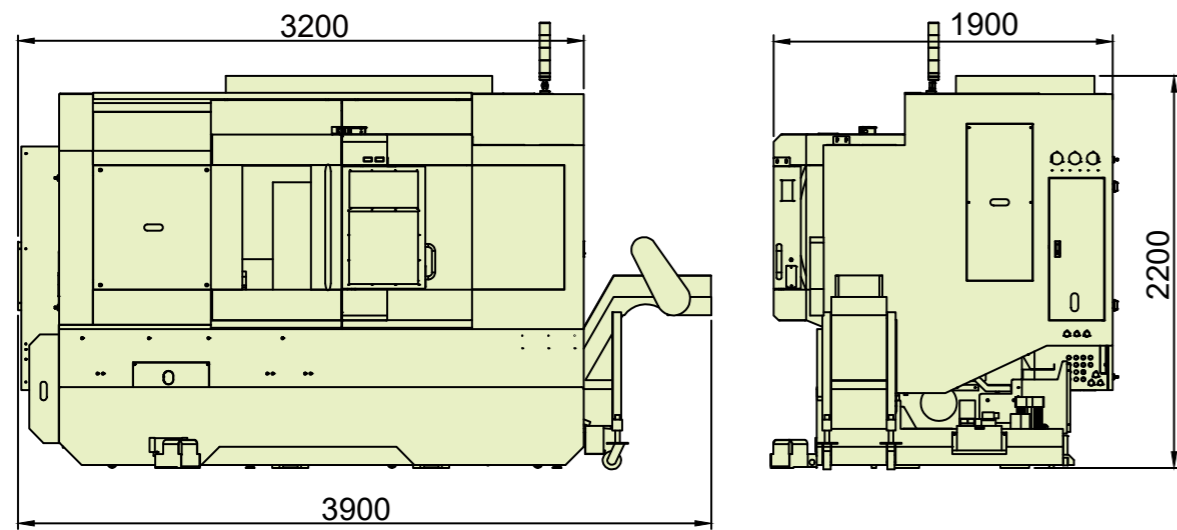

UT-300SY/UT-300Y

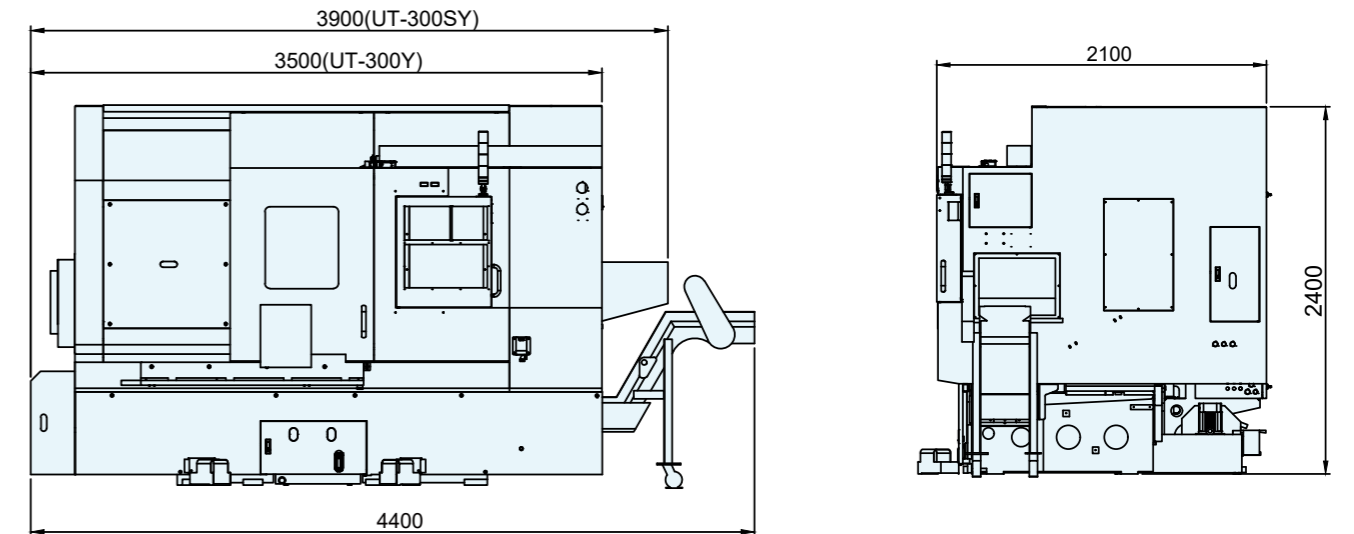

UA-200Y

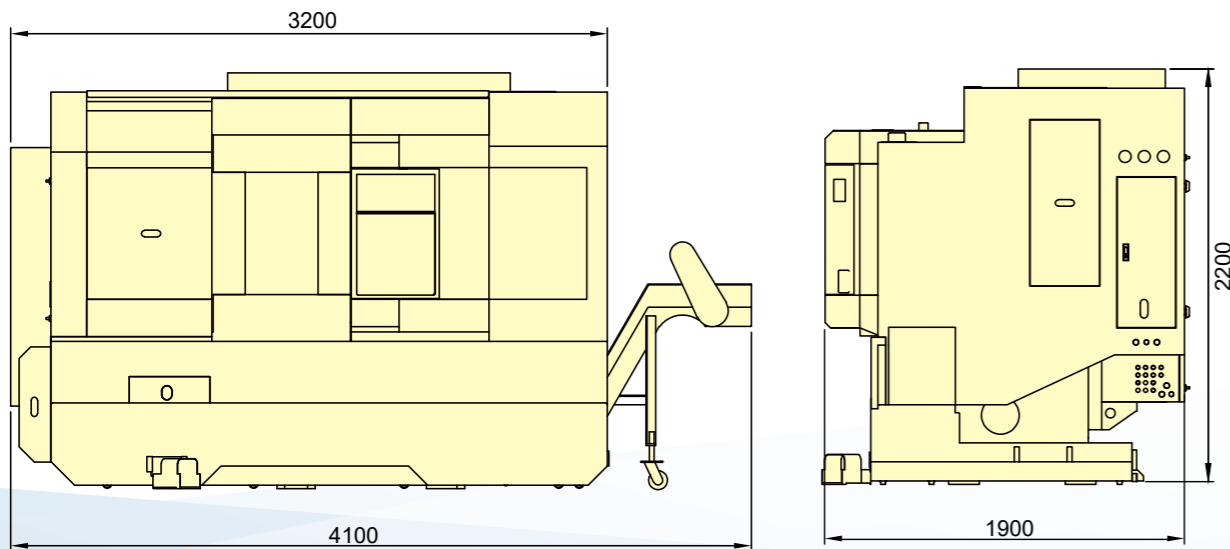

UA-330Y

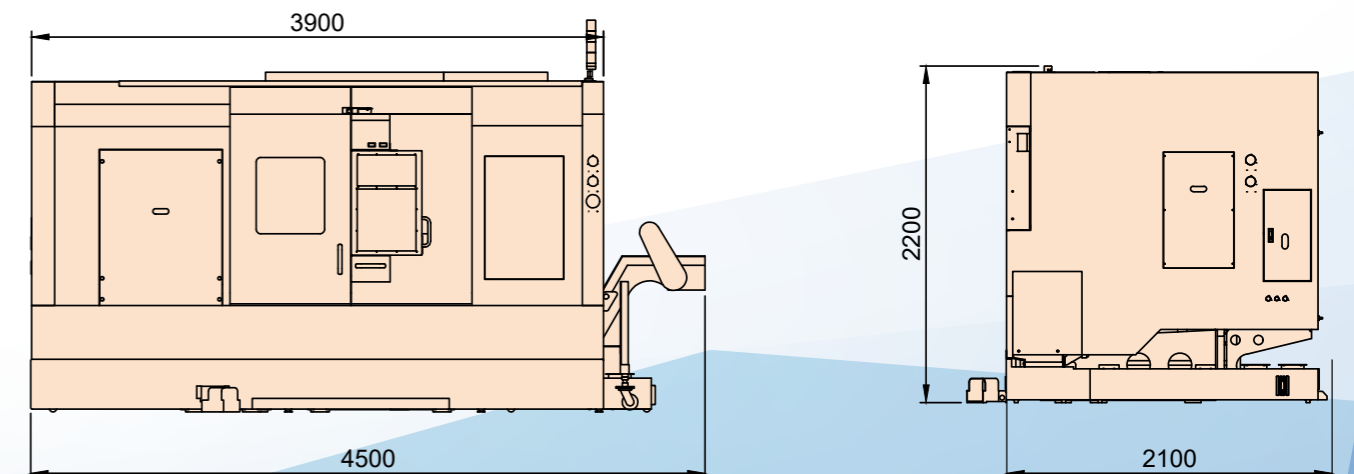

Specifications

Item / Model		UT-200S	UT-200SM	UT-200SY	UT-200Y	UA-200Y
Controller		FANUC 0i-T				
CAPACITY						
Swing Over Bed	mm	505	570	680		
Swing Over Saddle	mm	318	378	485		
Max. Turning Diameter(SP1)	mm	250	250	240	155	
Max. Turning Diameter(SP2)	mm	220		200	-	
Max. Turning Length	mm	480 (400)	440(360)		500 (425)	
Guideway Type		Box				
SPINDLE 1						
Spindle Nose Taper	ASA	A2-6(A2-5/A2-8)				
Chuck Diameter	inch	8 (6/10)				
Spindle Speed	rpm	4500 (6000/4000/3500)				
Spindle Motor Power(Cont./30min)	kW	11/15 (15/18.5)				
Bar Capacity	mm	52 (44/65/75)				
SPINDLE 2						
Spindle Nose Taper	ASA	A2-5	-			
Chuck Diameter	inch	6 (8)	-			
Spindle Speed	rpm	6000 (5000)	-			
Spindle Motor Power(Cont./30min)	kW	5.5 / 7.5	-			
Bar Capacity	mm	44	-			
TRAVELS						
X-axis Travel	mm	220				
Z-axis Travel	mm	600				
Y-axis Travel	mm	-	±50			
B-axis Travel	mm	585	-			
FEED RATES						
X-axis Rapid Traverse Rate	m/min	20				
Z-axis Rapid Traverse Rate	m/min	20				
Y-axis Rapid Traverse Rate	m/min	-	10			
B-axis Rapid Traverse Rate	m/min	20	-			
TURRET						
Tooling system		BOT	BMT(VDI)			
Turret Drive Type		Hydraulic/Servo	Servo mechanical			
Number Of Tools		12			15	
Square Tool Shank Size	mm	20			20	
Round Tool Shank Size	mm	32			25	
Max. Rotary Tool Speed	rpm	-	6000			
Rotary Tool Driver Power	kW	-	4.5	3.7 / 5.5		
TAILSTOCK						
Tailstock Body Travel	mm	-	545			
Quill Travel	mm	-	80			
Quill Diameter	mm	-	75			
Quill Taper	MT	-	4			
Tailstock Body Positioning		-	Programmable			
DIMENSIONS						
Machine dimension L x W x H	m	3.9 x 1.6 x 1.8	3.9 x 1.9 x 2.2		4.1 x 1.9 x 2.2	
Machine Weight	kg	4000	4500		5000	

Item / Model		UT-300S	UT-300SM	UT-300SY	UT-300Y	UA-330Y
Controller		FANUC 0i-T				
CAPACITY						
Swing Over Bed	mm	612	700	910	800	
Swing Over Saddle	mm	400	500	720	600	
Max. Turning Diameter(SP1)	mm	500	480	420	350	
Max. Turning Diameter(SP2)	mm	400	375		-	
Max. Turning Length	mm	610(540)	540(470)		640	
Guideway Type		Box				
SPINDLE 1						
Spindle Nose Taper	ASA	A2-8(A2-11)				
Chuck Diameter	inch	10/12 (15)				
Spindle Speed	rpm	3500 (2700/2500/2000)				
Spindle Motor Power(Cont./30min)	kW	15/18.5 (18.5/22)				
Bar Capacity	mm	75 (90/105/116.5)				
SPINDLE 2						
Spindle Nose Taper	ASA	A2-5				-
Chuck Diameter	inch	6 (8)				-
Spindle Speed	rpm	6000 (5000)				-
Spindle Motor Power(Cont./30min)	kW	5.5 / 7.5				-
Bar Capacity	mm	44				-
TRAVELS						
X-axis Travel	mm	300	280	275	290	
Z-axis Travel	mm	750				
Y-axis Travel	mm	-	±50			
B-axis Travel	mm	700				-
FEED RATES						
X-axis Rapid Traverse Rate	m/min	20				
Z-axis Rapid Traverse Rate	m/min	24				
Y-axis Rapid Traverse Rate	m/min	-	10			
B-axis Rapid Traverse Rate	m/min	20				-
TURRET						
Tooling system		BOT	BMT(VDI)			
Turret Drive Type		Hydraulic	Servo mechanical			
Number Of Tools		12			15	
Square Tool Shank Size	mm	25				
Round Tool Shank Size	mm	40				
Max. Rotary Tool Speed	rpm	-	4000			6000
Rotary Tool Driver Power	kW	-	4.5			3.7/5.5
TAILSTOCK						
Tailstock Body Travel	mm	-	540			
Quill Travel	mm	-	120			
Quill Diameter	mm	-	110			
Quill Taper	MT	-	5			
Tailstock Body Positioning		-	Programmable			
DIMENSIONS						
Machine dimension L x W x H	m	4.4 x 1.9 x 1.9	4.4 x 1.9 x 2.0	4.4 x 2.1 x 2.4	4.5 x 2.1 x 2.2	
Machine Weight	kg	5900	6000	6500	6700	

Specifications are subject to change without prior notice.